



Infrared resonance enhanced multi-photon ionization spectroscopy of C_{84}

G. von Helden^{a,b,*}, I. Holleman^{a,b}, M. Putter^{a,b}, A.J.A. van Roij^{a,b}, G. Meijer^{a,b}

^a Department of Molecular and Laser Physics, University of Nijmegen, Toernooiveld, NL-6525 ED Nijmegen, The Netherlands

^b FOM-Institute for Plasma Physics Rijnhuizen, Edisonbaan 14, NL-3430 BE Nieuwegein, The Netherlands

Received 9 July 1998; in final form 30 October 1998

Abstract

Gas-phase C_{84} is resonantly excited using infrared (IR) radiation from a free electron laser. At specific wavelengths, strong ion signals are observed, resulting from thermionic emission of electrons by the fullerenes. The mass-selected ion yield is recorded as a function of IR frequency and the resulting spectrum yields information on the electronic ground state of the gas-phase molecule. © 1999 Elsevier Science B.V. All rights reserved.

Spectroscopic data in the infrared (IR) spectral region contain a large amount of information on structure and dynamics of molecules. Such data are often difficult to obtain on gas-phase molecules, however, due to the absence of tunable, bright light sources and sensitive detection schemes in the IR. In the UV and visible part of the spectrum, multiphoton ionization techniques are routinely used to obtain spectra of molecules with very high sensitivities. In most of these experiments, however, information is limited to electronically excited states. To obtain IR spectral data on gas-phase molecules using sensitive ionization detection, a tunable IR laser has to be used as the excitation source, and several studies where one photon is in the IR exist. Most of these techniques, however, require a detailed knowledge of the properties of the electronically excited states and of the ionization potential of the molecule and often

involve complicated excitation and ionization schemes. It would be desirable to use a one-color resonance-enhanced multi-photon ionization (REMPI) scheme that provides IR spectral information, although it is not a priori clear how this could be accomplished.

The use of CO_2 lasers as ionization sources was first demonstrated by Bagratashvili et al. [1] and more recently by Hippler et al. [2]. Those experiments yielded no spectral information, however, since CO_2 lasers possess a limited (line) tuning range. In two recent publications [3,4], we demonstrated that IR spectral information can be obtained from multiphoton ionization of gas-phase molecules using intense tunable IR light. In those experiments, C_{60} is resonantly excited by the radiation from a free electron laser (FEL). By scanning the wavelength of the laser, resonances are observed in the C_{60} ion yield, and it is found that the observed resonances correspond to the well-known IR absorption lines of C_{60} . The ionization mechanism is assumed to be a thermal process, in which vibrationally excited levels of

* Corresponding author. E-mail: gertvh@sci.kun.nl

the electronic ground state couple to states that correspond to those of the ion. Such a process has so far only been observed for metal clusters [5,6] as well as for fullerenes [7,8] and has received substantial experimental [7,8] as well as theoretical [9] attention. Most studies so far have concentrated on C_{60} , with only a few on large fullerenes [10–12], presumably because of all species that are known to undergo thermionic emission, C_{60} is the molecule that is easiest to handle and it represents one of the best understood large molecules.

Compared to C_{60} and C_{70} , much less is known about the structures of fullerenes with > 70 atoms. Reasons are not only that those species are more difficult to produce and purify, but also that some of them contain an isomeric mixture that is often difficult to separate. For some, the isomers that fulfill the isolated pentagon rule (IPR) are cataloged by Fowler [13]. Whereas C_{60} and C_{70} possess only one IPR fullerene, 24 different IPR structures are possible for C_{84} . For larger fullerenes, the number of possible IPR isomers increases dramatically. Soon after the first report on the isolation of the higher fullerene C_{84} [14] a considerable experimental [15–18] as well as theoretical [19–24] effort was launched towards

elucidating its structure(s). Based on NMR experiments [14,17], it is now agreed that samples mostly contain two isomers, one isomer with D_2 and one with D_{2d} symmetry [23]. The IR spectra of various isomers have been calculated [19,24,18], but we are aware of only one published experimental spectrum, which has a rather limited dynamic range [18].

Here, we present IR-REMPI data on C_{84} . The IR-REMPI method offers the opportunity to obtain IR spectral information on samples that are not available in large quantities and/or high purity since the technique offers a high sensitivity and is mass selective.

A scheme of the experimental apparatus is shown in Fig. 1. A beam of ‘higher fullerenes’ (MER) is generated by heating a sample containing 30% C_{84} (with the next most abundant fullerene being $< 15\%$) in a quartz tube to 700–850 K. The quartz tube is mounted on a movable probe and can be inserted through a load lock to allow reloading of the sample without disrupting the vacuum in the chamber. The heating element is mounted inside the vacuum chamber. In a typical experiment, < 1 mg of sample is found to be sufficient to allow several hours of stable operation. The effusive beam is intersected by the IR

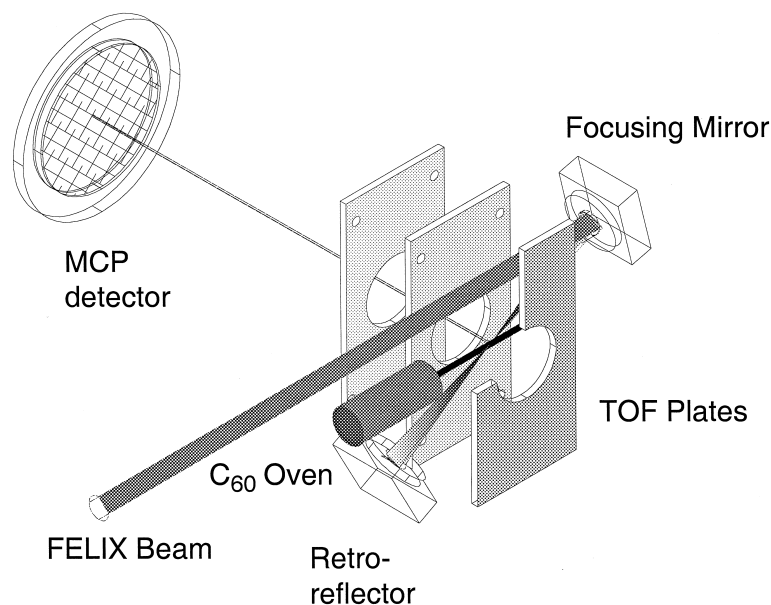

Fig. 1. Scheme of the experimental arrangement. An effusive beam of ‘higher fullerenes’ originates from a quartz oven and is crossed by the IR laser beam in the center between two electrodes. The laser produced ions are accelerated and detected on a multichannel plate detector.

laser beam between the plates of a time-of-flight (TOF) mass spectrometer. The IR light beam enters the experimental apparatus several cm higher and co-propagates the fullerene beam. A spherical mirror with a focal length of 7.5 cm focuses the IR light on the fullerene beam. A second mirror, again at a distance of 7.5 cm from the focus, acts as a retro-reflector and focuses the IR beam such that both foci overlap, resulting in a doubling of the micropulse repetition rate in the focus (see below). The optical cavity is inclined with respect to the molecular beam to increase the interaction time of the molecules with the focused IR light.

The TOF consists of three rectangular stainless-steel plates that are 1.5 cm apart. The center of the plates consists of a circular grid pattern of 2.5 cm diameter and 75% transparency to let ions pass through while keeping the fields homogeneous. Ions are detected on a MCP detector at a distance of 45 cm from the last TOF plate. The first two TOF plates can be pulsed from ground to high voltage (5 and 4 kV) at a variable delay after the IR laser pulse.

The ‘free electron laser for infrared experiments’ (FELIX) user facility in Nieuwegein, The Netherlands [25] and its application to IR-REMPI experiments [3,4] has been described in detail previously.

Briefly, the laser produces IR radiation that is continuously tunable over the 100–2000 cm^{-1} range. The light output consists of macropulses at 10 Hz of ~ 5 μs duration containing up to 100 mJ of energy. Such a macropulse consists of a train of micropulses with a typical duration of 0.3–3 ps that are 1 ns apart. The cavity formed by the two focusing mirrors doubles the micropulse repetition rate in the laser focus to 2 GHz. About 30 μs after the end of the FELIX macropulse, the TOF plates are pulsed to high voltage. Ions are detected on a MCP detector and the signal is recorded on a digital oscilloscope (LeCroy 9430). IR-REMPI spectra are recorded by measuring the intensity at each mass as a function of the FELIX wavelength.

In Fig. 2, mass spectra that are obtained when the effusive beam of ‘higher fullerenes’ is irradiated with FELIX at different wavelengths are shown. The spectra are taken by continuously scanning the IR wavelength and averaging mass spectra over a ± 0.5 μm region around the central wavelengths that are indicated in the figure. Clearly, the mass distributions obtained are critically dependent on the IR wavelength used. At 20.9 μm , a peak of C_{84}^+ is observed, accompanied by smaller amounts of C_{82}^+ and C_{86}^+ .

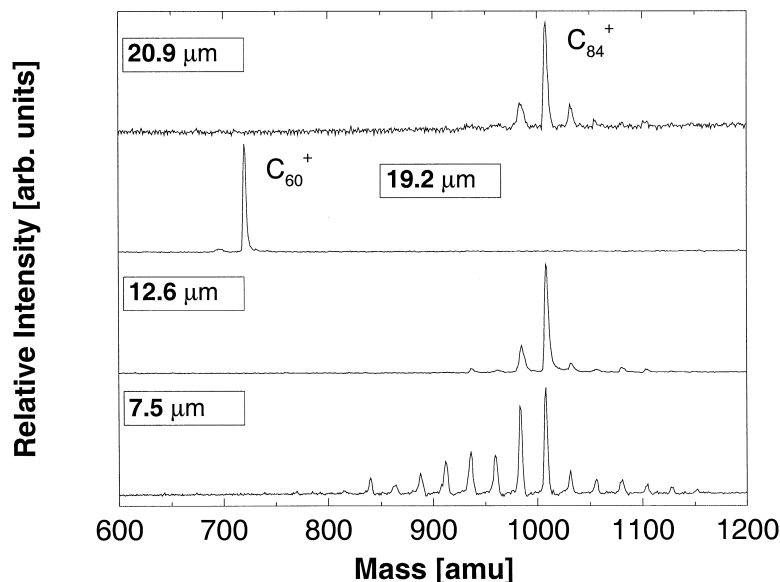

Fig. 2. Mass spectra obtained when irradiating the effusive beam of ‘higher fullerenes’ with FELIX at different wavelengths.

the C_{84}^+ peak completely disappears and a large peak of C_{60}^+ is observed. The distribution at $12.6 \mu\text{m}$ is rather similar to the one observed at $20.9 \mu\text{m}$. A very different distribution is observed at $7.5 \mu\text{m}$. Here, the distribution is very wide, ranging from C_{70}^+ to beyond C_{96}^+ with every C_{2n}^+ in-between being present.

IR-REMPI spectra of a certain fullerene are obtained by recording the total area of the corresponding parent ion peak in the TOF mass spectra as a function of IR wavelength. In Fig. 3, the thus obtained IR-REMPI spectra of C_{60} and C_{84} are shown. As reported previously [3,4], the peaks in the C_{60} IR-REMPI spectrum correspond to the four well-known IR absorption bands of C_{60} [26] plus two peaks around 1500 cm^{-1} that result from IR combination bands. The relative peak intensities depend strongly on characteristics of the laser beam such as power, fluence and bandwidth. Relative intensities in a spectrum are therefore subject to the tuning characteristics of the laser and are only qualitatively meaningful.

The C_{84} spectrum shown in the top part of Fig. 3 is very different and exhibits a much richer structure than the C_{60} spectrum. It consists of three peaks at 475 , 632 and 784 cm^{-1} , followed by a series of partially unresolved peaks, ranging from 1050 to 1600 cm^{-1} . It should be noted that the peak at 475 cm^{-1} is the lowest-frequency IR-REMPI peak obtained so far. In order for the molecule to acquire the energy necessary for autoionization ($40\text{--}50 \text{ eV}$ [9]) > 800 photons have to be absorbed by a single molecule at that wavelength!

The IR-REMPI spectrum of C_{84} can be compared to calculated IR absorption spectra. C_{84} has 24 IPR isomers of which two are observed in the experiment [23]. Shown in Fig. 4 is the experimental IR-REMPI spectrum of C_{84} together with the calculated spectra for the two observed isomers, the D_2 and the D_{2d} isomer (Nos. 22 and 23 in the listing of Fowler and Manolopoulos [13]). Harmonic frequencies and IR intensities are calculated using a PM3 semiempirical [27] hamiltonian as implemented in the program Gaussian 94 [28]. The spectra shown are obtained by

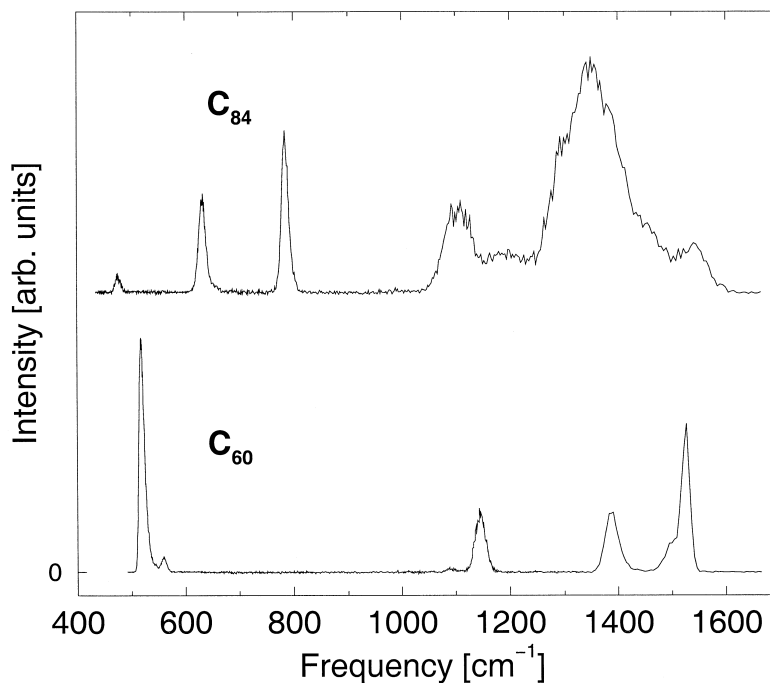

Fig. 3. Infrared resonance enhanced multiphoton ionization (IR-REMPI) spectra of C_{60} and C_{84} .

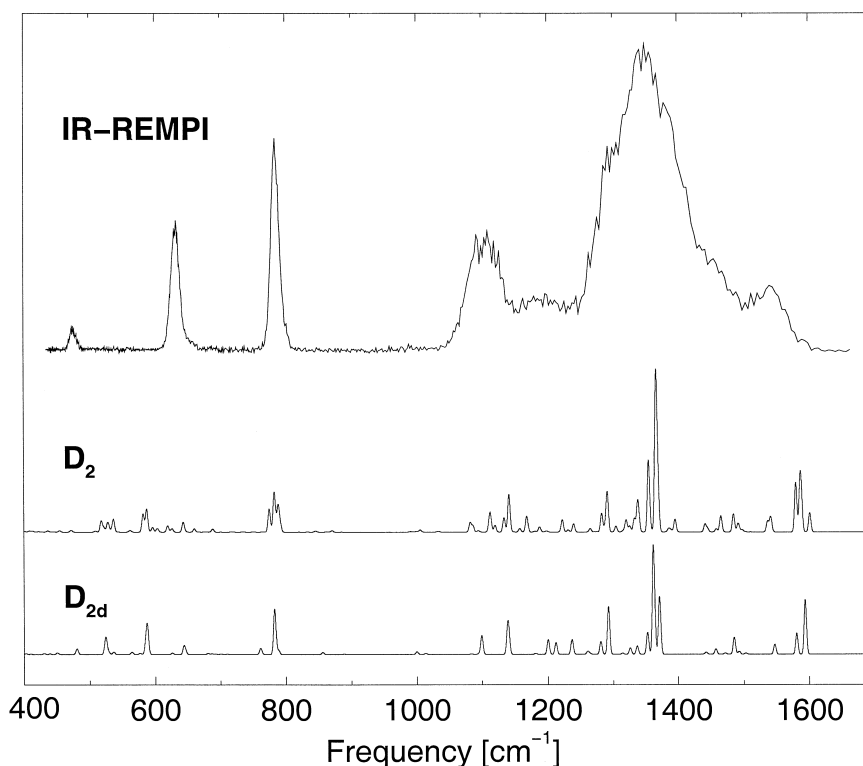

Fig. 4. IR-REMPI spectrum of C_{84} together with calculated IR absorption spectra.

scaling the calculated frequencies by 0.85 and convoluting the lines with a 5 cm^{-1} wide Gaussian. Not surprisingly, these spectra are very similar to those calculated using a similar method [24]. The two calculated spectra resemble each other, the difference being that the D_2 isomer shows more IR active lines due to splitting of the lines from the higher-symmetry D_{2d} isomer. However, these splittings are much too small to be resolved in the IR-REMPI spectrum.

Both calculated IR absorption spectra look similar to the experimental IR-REMPI spectrum. A priori, it is not clear whether this is expected. As we showed previously [3,4], the peak intensities in an IR-REMPI spectrum can be non-trivially related to the excitation laser bandwidth and fluence. For an IR-REMPI peak to be observed, a prerequisite is that an IR active mode is present in the IR absorption spectrum within a few wavenumbers. The reverse does not need to be true, i.e. the presence of an IR active mode does not necessarily give rise to a peak in the IR-REMPI spectrum. It could be, for example, that

an IR active mode possesses a large anharmonicity and is therefore not long enough in resonance with the excitation laser for the molecule to reach excitations high enough for autoionization. Nonetheless, the resemblance of the two calculated spectra with the IR-REMPI spectrum is striking. It thus seems that most IR active modes in the molecule do give rise to peaks in the IR-REMPI spectrum.

A possible complication is that the fullerene mix used contains only $\sim 30\%$ of C_{84} and substantial amounts of other fullerenes ranging from C_{76} to beyond C_{100} . The IR-REMPI spectrum could therefore be influenced by fragmentation of larger fullerenes, such as C_{86} . When exciting with low-frequency light, it is observed that fragmentation is largely absent [3,4] and results in a maximum fragmentation of $\sim 5\%$ at the excitation powers used in this experiment. Since in addition C_{86} is only a minor constituent in the sample used, it is not expected that fragmentation is influencing the IR-REMPI spectrum in the low-frequency part. This situa-

tion is different for the higher-frequency part of the spectrum between 1000 and 1600 cm^{-1} . There, fragmentation is found to be substantial, even at moderate excitation powers. The spectrum shown in Figs. 3 and 4 is therefore recorded while using low FELIX powers, thus avoiding perturbation of the IR-REMPI spectrum as much as possible.

In principle, IR-REMPI spectra of all fullerenes in the sample can be obtained simultaneously by recording the intensity of their mass peaks as a function of IR wavelength. In practice, however, this can lead to ambiguous results when a fullerene is present in minor concentrations and the next higher fullerene is abundant. In such a case, spectra have to be recorded at very low IR powers to avoid the problems associated with fragmentation. Nonetheless, IR-REMPI presents a unique possibility in the study of IR spectra of higher fullerenes and experiments to obtain spectra of other interesting fullerenes are presently being pursued in our laboratory.

Acknowledgements

We gratefully acknowledge the support by the ‘‘Stichting voor Fundamenteel Onderzoek der Materie’’ (FOM) in providing the required beam time on FELIX and highly appreciate the skillful assistance by the FELIX staff. This work is part of the research program of the FOM, which is financially supported by the ‘‘Nederlandse Organisatie voor Wetenschappelijk Onderzoek (NWO)’’, and receives direct support by the NWO via PIONIER-grant # 030-66-089. This work was also supported in part under the TMR ‘‘Access to large-scale facilities’’ programme of the European Community.

References

- [1] V.N. Bagratashvili, M.V. Kuz'min, V.S. Letokhov, A.N. Shibanov, *JETP Lett.* 37 (1983) 112.
- [2] M. Hippler, M. Quack, R. Schwarz, G. Seyfang, S. Matt, T. Märk, *Chem. Phys. Lett.* 278 (1997) 111.
- [3] G. von Helden, I. Holleman, G.M.H. Knippels, A.F.G. van der Meer, G. Meijer, *Phys. Rev. Lett.* 79 (1997) 5234.
- [4] G. von Helden, I. Holleman, A.J.A. van Roij, G.M.H. Knippels, A.F.G. van der Meer, G. Meijer, *Phys. Rev. Lett.* 81 (1998) 1825.
- [5] T. Leisner, K. Athanassenas, O. Echt, O. Kandler, D. Kreisler, E. Recknagel, *Z. Phys. D* 20 (1991) 127.
- [6] A. Amrein, R. Simpson, P. Hackett, *J. Chem. Phys.* 94 (1991) 4663.
- [7] E.E.B. Campbell, G. Ulmer, I.V. Hertel, *Phys. Rev. Lett.* 67 (1991) 1986.
- [8] P. Wurz, K.R. Lykke, *J. Chem. Phys.* 95 (1991) 7008.
- [9] C.E. Klots, R.N. Compton, *Surface Rev. Lett.* 3 (1996) 535, and references therein.
- [10] S. Maruyama, M.Y. Lee, R.E. Haufler, Y. Chai, R.E. Smalley, *Z. Phys. D* 19 (1991) 409.
- [11] E.E.B. Campbell, G. Ulmer, I.V. Hertel, *Z. Phys. D* 24 (1992) 81.
- [12] K.W. Kennedy, O. Echt, *J. Phys. Chem.* 97 (1993) 7088.
- [13] P.W. Fowler, D.E. Manolopoulos, *An Atlas of Fullerenes*, Oxford University Press, Oxford, 1995.
- [14] F. Diederich, R. Ettl, Y. Rubin, R.L. Whetten, R. Beck, M. Alvarez, S. Anz, D. Sensharma, F. Wudl, K.C. Khemani, A. Koch, *Science* 252 (1991) 548.
- [15] K. Kikuchi, N. Nakahara, T. Wakabayashi, M. Honda, H. Matsumiya, T. Moriwaki, S. Suzuki, H. Shiromaru, K. Saito, K. Yamauchi, I. Ikemoto, Y. Achiba, *Chem. Phys. Lett.* 188 (1992) 177.
- [16] F. Diederich, R.L. Whetten, *Acc. Chem. Res.* 25 (1992) 119.
- [17] K. Kikuchi, N. Nakahara, T. Wakabayashi, S. Suzuki, H. Shiromaru, Y. Miyake, K. Saito, I. Ikemoto, M. Kainosho, Y. Achiba, *Nature (London)* 357 (1992) 142.
- [18] M. Hulman, T. Pichler, H. Kuzmany, F. Zerbetto, E. Yamamoto, H.N. Shinohara, *J. Mol. Struct.* 408/409 (1997) 359.
- [19] K. Raghavachari, C.M. Rohlfing, *J. Phys. Chem.* 96 (1991) 5768.
- [20] K. Raghavachari, *Chem. Phys. Lett.* 190 (1992) 397.
- [21] B.L. Zhang, C.Z. Wang, K.M. Ho, *J. Chem. Phys.* 96 (1992) 7183.
- [22] M. Bühl, C. van Wüllen, *Chem. Phys. Lett.* 247 (1995) 63.
- [23] D.E. Manolopoulos, P.W. Fowler, R. Taylor, H.W. Kroto, D.R.M. Walton, *J. Chem. Soc., Faraday Trans.* 88 (1992) 3117.
- [24] D. Bakowies, M. Kolb, W. Thiel, S. Richard, R. Ahlrichs, M.M. Kappes, *Chem. Phys. Lett.* 200 (1992) 411.
- [25] D. Oepts, A.F.G. van der Meer, P.W. van Amersfoort, *Infrared Phys. Technol.* 36 (1995) 297.
- [26] D.S. Bethune, G. Meijer, W.C. Tang, H.J. Rosen, *Chem. Phys. Lett.* 174 (1990) 219.
- [27] J.J.P. Stewart, *J. Comput. Chem.* 10 (1989) 209.
- [28] M.J. Frisch, G.W. Trucks, H.B. Schlegel, P.M.W. Gill, B.G. Johnson, M.A. Robb, J.R. Cheeseman, T. Keith, G.A. Petersson, J.A. Montgomery, K. Raghavachari, M.A. Al-Laham, V.G. Zakrzewski, J.V. Ortiz, J.B. Foresman, J. Cioslowski, B.B. Stefanov, A. Nanayakkara, M. Challacombe, C.Y. Peng, P.Y. Ayala, W. Chen, M.W. Wong, J.L. Andres, E.S. Replogle, R. Gomperts, R.L. Martin, D.J. Fox, J.S. Binkley, D.J. Defrees, J. Baker, J.P. Stewart, M. Head-Gordon, C. Gonzalez, J.A. Pople, *Gaussian 94, Revision D.3*, Gaussian, Inc., Pittsburgh, PA, 1995.